

RainSoft Division of Aquion Water Treatment Products
2080 East Lunt Avenue
Elk Grove Village, Illinois 60007
1.847.437.9400 or 1.800.860.7638
www.rainsoft.com

RainSoft®

Water Treatment Systems
Since 1953

GOLD SERIES WATER TREATMENT SYSTEM

Owner's Manual



This product is manufactured in an ISO 9001:2000 certified facility.



The Gold Series is tested and certified by the WQA to NSF/ANSI Standard 44 for the specific performance claims as verified and substantiated by test data. See the performance data sheets for specific reduction claims.

Part No.: 15860b
Revised: 12/06
For use in California

Table of Contents

Information on Water Treatment Systems	3
Application Limitations	3
Operational Specifications.....	4
Salt Requirements.....	5
Resin Cleaners.....	5
Installation Instructions	6 – 8
System Start Up.....	9
System Settings	10
Troubleshooting Guide	11
Exploded Views and Parts Lists	12 – 15
Warranty Information	16
Installer Specification Sheet	17
California Performance Data Sheets	18 – 20

Congratulations! You now own the finest RainSoft Water Treatment System available to homeowners. To enjoy the maximum benefits of this system, please read the contents of this Owners Manual.

Information on Water Treatment Systems

There are many misconceptions that people have developed about water treatment systems. The most common topic of confusion is the amount of sodium (Na), not table salt (NaCl), that is added to the water from a water conditioner. In reality, ion exchange does replace the hardness ions in your water with sodium ions, but the common misconception is the amount used.

For every 1 grain of hardness, the exchange process will deliver approximately 8 milligrams of sodium per 1 liter of water. The amount of sodium present in a standard 8 ounce glass of treated water, that was 10 grains hard prior to treatment, would be around 19 milligrams of sodium. This is an insignificant amount of sodium considering a typical slice of white bread has about 140 milligrams.

Another common misconception of water treatment systems is the idea that soft water will produce clear ice cubes. Cloudy or white, hazy ice cubes are caused by air that is slowly being released from the water during the freezing process, which has nothing to do with the performance of your system.

The last misconception that needs mentioning is the amount of salt used by the conditioner to regenerate the system. People seem to think that water conditioners use an enormous amount of salt, which may have been the case in the past, but that was due to old technology and standards. Water conditioners do use salt for regeneration, but the amount of salt varies by water consumption. The more water that needs to be conditioned, the more times the system will regenerate, resulting in the use of more salt. Fortunately, today's technology allows us to dispense just the right amount of salt for maximum efficiency, based on your individual water consumption needs.

Application Limitations

On hardness levels of 60 grains and higher, the system may not achieve a hardness of less than 1 grain, due to high Total Dissolved Solids. (Some bleed through is possible.) Bleed through can also be caused by sodium levels higher than 1000 parts per million. In either case, your system can be programmed to minimize these effects. See your RainSoft Dealer for details.

Chlorine or Chloramine levels on municipality treated water should not exceed 4 parts per million.* When Chlorine or Chloramine levels are 4 parts per million* or greater, it can have adverse effects on your system. In applications where high levels are a concern, pre-filtration is necessary to reduce the Chlorine or Chloramine to an acceptable level. See your RainSoft Dealer for details.

When this system is installed on water with Ferrous iron, also known as clear water iron, the maximum range of removal is based on local water conditions. The range is generally 2 to 10 parts per million. Your equipment may require special programming, along with an additive to the brine tank, to maximize the equipment's ability to remove iron. See your RainSoft Dealer for details.

! Important Note: This system may be installed on well water or municipality treated water supplies.

! Important Note: Most municipality treated water supplies contain Chlorine as a disinfectant. Many municipalities also inject ammonia into the water supply, creating Chloramine.

*** Maximum disinfectant level of Chlorine or Chloramine recommended from the EPA.**

! Important Note: Oxidized or Ferric iron will foul the mineral bed. Iron fouled resin is not eligible for warranty replacement.

Operational Specifications

Plumbing

3/4 inch to 1 1/4 inch

Drain Line

1/2 inch

Water Pressure

20 psi – 120 psi (1.38 bar – 6.89 bar)

Operating Temperatures

40° F – 100° F (4.4° C – 37.8° C)

Electrical Requirements

A properly grounded alternating current supply (110 VAC 60 Hz or 230 VAC 50 Hz) is required for the operation of this system. Please check the transformer for the correct voltage requirements.

! Important Note: This system requires the use of the supplied transformer (24 VAC).

Bypass Valve

The bypass valve enables you to bypass the system in situations of: emergency leaks in the equipment, service calls and/or outdoor water use.

! Important Note: The manually operated bypass valve enables the conditioner to be isolated from the water service line for maintenance and service. It also maintains the continuity of the water supply when the conditioner is disconnected.

Existing Plumbing Conditions

Plumbing should be free from lime and/or iron buildup. Piping that contains large amounts of lime and/or iron should be replaced. If piping is clogged with iron, a separate iron filter should be installed in-line, before the water conditioner.

Additional Specifications

Do not install this system where water is microbiologically unsafe or of unknown quality without adequate disinfection before or after the system.

This system must be installed in accordance with all applicable state and local laws and regulations.

This system must be installed in an area not affected by extreme heat, cold or the elements. The selected installation area must be adequate for easy service of all parts.

This system is designed to treat cold water only. The installation must be on a cold water supply.

Resin Data Chart

Model	Tank Size	Resin** cu. ft.	Service Flow	Drain Flow	Psi Drop	High Salting	Medium Salting	Low Salting	Efficiency***
AQC 75 CV	8 x 44	0.75	9.3	1.50	15	28,100 @ 11.2 lbs.	24,000 @ 7.5 lbs.	13,400 @ 3.0 lbs.	4,470
AQC 100 CV	10 x 44	1.00	10	2.0	12	37,700 @ 15.0 lbs.	32,300 @ 10.0 lbs.	14,900 @ 3.0 lbs.	4,970
LQC 60 CT	10 x 35	0.60	10	2.00	10	15,000 @ 9.0 lbs.	11,800 @ 6.0 lbs.	6,800 @ 2.4 lbs.	N/A
AQC 100 CT	10 x 44	1.00	10	2.00	13	25,800 @ 15.0 lbs.	25,700 @ 10.0 lbs.	12,200 @ 3.0 lbs.	4,070

** Cation Exchange Media

*** The conditioners are efficiency rated according to NSF/ANSI 44. The efficiency of the conditioner is valid only at the stated salt dosage.

Salt Requirements

Two salt types are recommended for water conditioners:

1. Block Salt: Water conditioner block salt is reasonably priced, low in impurities and will not cake in the salt container.
2. Solar Salt: Solar salt is 98% pure salt, reasonably priced and low in impurities.

Resin Cleaners

It is always wise to provide preventative maintenance for your system. If small amounts of iron are present in your water, use a salt containing iron remover or add iron remover to the resin cleaner when adding salt. If an excessive amount of iron is present in your water, we recommend the installation of an iron filter before the conditioner. See your RainSoft Dealer for details.

Maintenance Requirements

Cleaning the Regeneration Valve

The regeneration valve is designed to last a lifetime, but from time to time it may be necessary to clean and lubricate the moving parts. Your water quality and the amount of regeneration necessary will affect this maintenance schedule. Your local RainSoft Dealer is knowledgeable in the different water qualities and will have the necessary parts to complete this service.

Testing Your Water

A hardness test strip is provided to ensure that the system is performing properly and that hardness is being reduced. Additional hardness test strips are available at no charge from RainSoft. Please call 1-800-860-7638 for your free two year supply.

In between testing, you can easily monitor the system's performance in the shower or while washing your hands. The feeling of soft water should be present on your skin.

Product Certification Information

The Gold Series is tested and certified by the WQA to NSF/ANSI Standard 44 for the specific performance claims as verified and substantiated by test data. Please refer to the performance data sheets for specific reductions claims.

Water treatment devices sold to retail consumers in California, accompanied by certain health claims, must be certified by the State of California Department of Health Services. These units are not certified by the State of California for the purpose of making health claims.

 **Helpful Tip:** For maximum satisfaction, add salt before the salt container is empty.

 **Important Note:** Rock salt is not recommended for RainSoft water conditioners. If rock salt is used, the salt container must be cleaned out periodically. **DO NOT USE GRANULATED SALT!** The use of granulated salt may cause service problems.

 **Helpful Tip:** Resin cleaner will prevent the treatment media from becoming iron fouled.

 **Important Note:** If you use a cleaner containing nitric acid or other strong oxidizing agents, please use caution and follow instructions carefully.

 **Helpful Tip:** We recommend that this service be performed every three years or earlier if necessary.

 **Helpful Tip:** As an additional reminder, your system is equipped with a low salt alarm to inform you that the system is low on salt, which will also affect the performance of the system.

Installation Instructions

1. Safety Precautions

- To prevent accident or injury, do not hoist the unit over your shoulder. Use a hand truck to transport the unit.
- Do not lay the unit on its side.
- Wear safety glasses and work gloves during installation and service.

2. Test the Raw Water

- Test the raw water for hardness, iron and/or any other element that could affect the performance of the system.

3. Check the Water Pressure

- Use a pressure gauge to confirm that the water pressure does not exceed 120 psi. If the water pressure does exceed this limit, install a pressure regulator on the inlet pipe of the unit. The minimum water pressure for a conditioner is 20 psi. 60 psi is the optimum operating pressure.

4. Locate a Site for the System

- There are three primary requirements needed for a site: the main water source, a drain and an electrical connection. Locate the system as close to these items as practical. Avoid drain lines over 25 feet long. In most applications, bypass any outside faucets.
- Place the system in the desired location. The location should have a level, smooth, and clean surface.
- If the system is located outdoors, protect the unit from direct sunlight. Direct sunlight can damage the fiberglass and other system components. If necessary, build a box or shed.

 **Helpful Tip:** The drain may be a floor drain, a sewer trap, utility sink, vent stack, dry well, etc., depending on local plumbing codes.

5. Install the Valve Head (Not Applicable for LQC Models)

- Remove the cap plug from the tank.
- Lubricate the riser pipe o-ring and tank o-ring with the proper silicone lubricant.
- Align the control valve with the riser pipe and slowly lower the control valve onto the riser pipe, using a twisting motion.
- Align the control valve with the tank. Push down on the control valve and continue to turn it clockwise until the valve o-ring seals against the tank.

 **Important Notes:** The system can only be installed outdoors in climates that do not reach freezing levels.

6. Turn Off the Water and Drain the Plumbing

- Turn off the water at the meter or the pressure tank.
- Drain all the pipes. Do not sweat pipes with water in them; steam will damage the plastic parts in the valve.
- To drain the plumbing system, open all the faucets in the house and flush the toilets. The water will drain out of the lowest faucet or outlet.

 **Important Note:** Do not over-tighten the valve to the tank.

 **Helpful Tip:** This procedure will allow air to enter the plumbing system.

7. Bypass the Outside Faucets

- Install plumbing pipes to bypass the outside faucets. If the plumbing is not accessible, provide an untreated hose bib on the inlet pipe.

8. Install the Pipe Connector (Yoke) to the Bypass Valve

- Once the plumbing is complete, connect the yoke to the bypass valve (see figure 1).

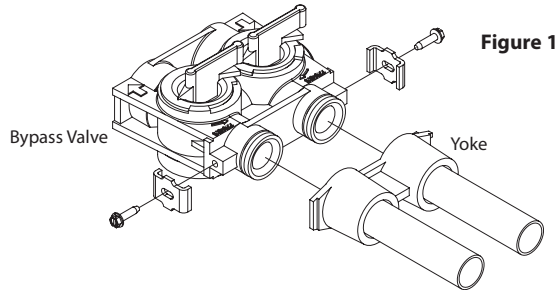

Figure 1

- Support all plumbing connected to the yoke.
- Do not point the soldering torch directly at the mineral tank or control valve. These composite materials will last a lifetime, but cannot withstand the intense heat from a torch.
- Avoid short connections of pipe between the system and the water heater. If you can't avoid a short connection, move the system to another location. As a last resort, install a heat trap or check valve. If this causes "water hammer", install a water hammer suppressor.
- Connect the raw water supply to the inlet pipe connection of the yoke. When looking at the front of the system, the inlet is the pipe connection on the right side of the valve (see figure 2). The arrow molded into valve indicates the direction of flow.
- Connect the treated water pipe to the outlet pipe connection on the yoke. When looking at the front of the system, the outlet is the pipe connection on the left side of the valve (see figure 2). The arrow molded into the valve indicates the direction of flow.

! Important Note: The bypass valve is not designed to withstand heat from soldering or twisting from the attached threaded connections.

! Important Note: Too much weight on the plumbing connections will cause a leak.

! Important Note: Short connections of pipe may allow hot water to back up into the system.

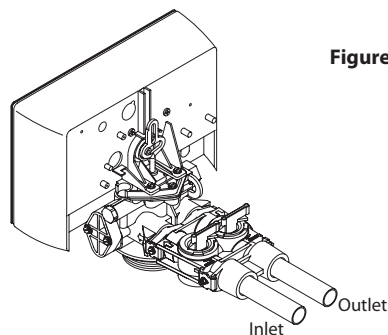

Figure 2

9. Set the Bypass Valve to Bypass

- Move the bypass valve handles to the bypass position. The valve handles should be perpendicular to the pipes (see figure 3).

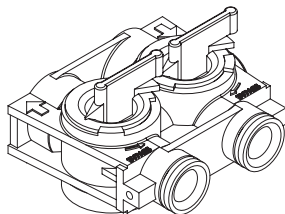
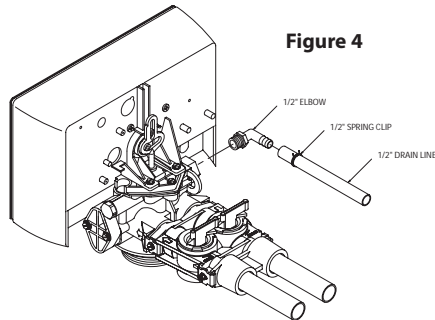

Figure 3

10. Install the Drain Line and Air Gap (Air Gap Not Supplied)

- For all drain lines, use at least a 1/2 inch ID line.
- Connect the drain line to the drain outlet on back of the valve, opposite the inlet connection (see figure 4). A fitting is required to connect the female pipe thread to the drain line.



- Run the drain line to the air gap. The air gap must be installed between the end of the drain line and the drain to prevent possible back siphoning (see figure 5).

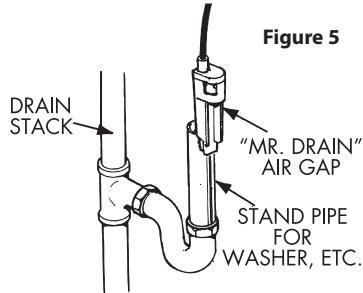

Important Note: The air gap should be two times the diameter of the drain line or a minimum of two inches. Please check your local plumbing codes to ensure compliance.

11. Attach the Electrical Connection

- Remove the supplied wire from the warranty pack.
- Attach the U shaped connectors (supplied) to the wire with a crimping tool (not supplied).
- Connect the wire to the transformer (see figure 6).
- Insert the other end of the wire, with the connector, into the back of the control box (see figure 6).

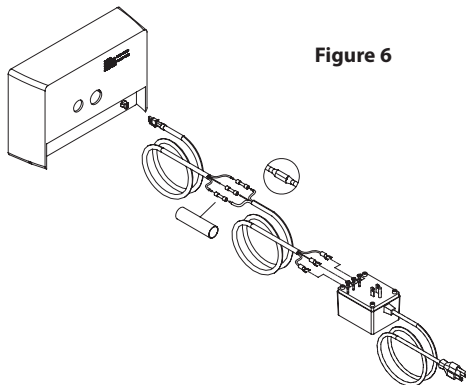

Helpful Tip: If the wire is too short, use the supplied connectors and shrink tubing in the warranty pack to lengthen the wire.

Helpful Tip: Squeeze the connector to release it from the box.

- Plug the transformer into a 110 VAC 60 Hz or 230 VAC 50 Hz outlet.

Helpful Tip: Check the transformer label for the correct voltage requirement.

System Start Up

1. Turn on the Water and Check for Leaks

- Close all faucets and turn the water back on at the water meter or pressure tank.
- Check for leaks. If a leak is present, drain the plumbing again before soldering.

2. Flush the Remaining Debris from the System

- Open the cold water faucet on your bathtub.
- Allow the system to flush the remaining dirt and debris into the bathtub, until the water runs clear.
- Open all remaining faucets and allow the plumbing to release any trapped air in the system.
- Close all of the faucets.

3. Open the Bypass Valve

- Move the bypass valve handles to the service position. The valve handles should be parallel to the pipes (see figure 7).

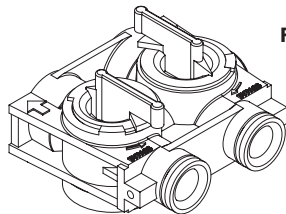

Figure 7

- Open the bathtub faucet again and allow the system to fill with water for approximately 5 minutes.

4. Flush the Remaining Untreated Water from the Water Heater

- Run hot water in the bathtub until the water tests soft.

5. Program the Computer

- Please refer to the System Settings on page 12.

6. Sanitize the Conditioner

- Mix a 3/4 cup of common (unscented) 5.25% household bleach with 1 quart of water. Pour this solution into the brine well.
- Initiate a manual regeneration. The solution will be drawn into the conditioner during the regeneration process.
- After the system has completed a manual regeneration, the conditioner will be sanitized and ready for use.

 **Helpful Tip:** This procedure will prevent dirt and debris from entering the valve.

 **Helpful Tip:** It is common for new systems to have some color in the water. The color should disappear after you completely flush the system.

 **Important Note:** Do not pour undiluted bleach into the water conditioner.

System Settings

The program/enter button is used as an “enter” or a “scroll” button when programming the system. The program/enter button allows you to access the four basic settings: **S** – Salt Level, **A** – Salt Alarm, **h** – Hour of Regeneration and **P** – Present Time of Day.

How to Adjust the Salt Pounds (S)

To set or change the salt level in the brine tank, press the program/enter button and wait for the computer to display the salt level. Use the up or down arrow to enter the closest level value that is indicated on the corresponding scale. Each level on the scale represents 50 pounds of salt. Once the desired salt level has been entered, the program/enter button must be pressed again for the computer to accept the new setting.

 **Helpful Tip:** The scale for block salt is designated by levels 1 – 4. The scale for bag salt or potassium chloride is designated by levels 1 – 5. For larger tanks, a salt scale sticker is available through your RainSoft Dealer, part number 19024.

Potassium Chloride may be used as a substitute for salt.

Salt Alarm (A)

This option allows you to set the salt alarm to your desired time. To set or change the salt alarm, press the program/enter button 2 times; the computer will display **A**. Use the up or down arrow to set the alarm time. To disable the alarm, use the up or down arrow to reach the 12 A.M. – 1 A.M. time; “OFF” will be displayed on the computer and the alarm will be disabled. Once the desired alarm time or disable request has been entered, the program/enter button must be pressed again for the computer to accept the new setting.

A low salt alarm will sound when the salt in the brine tank becomes lower than the desired level (30 lbs. or less). The alarm has been set to sound at 5 P.M., but you do have the option to change this setting. When the low salt alarm does go off, press the program/enter button and wait for the **S** to appear. After the salt level has been displayed, add salt and press the program/enter button.

How to Adjust the Hour of Regeneration (h)

To set or change the time of regeneration, press the program/enter button 3 times; the computer will display **h**. Use the up or down arrow to scroll through the A.M. and P.M. times, until the desired hour of regeneration is reached. Once the desired time of regeneration has been entered, the program/enter button must be pressed again for the computer to accept the new setting.

 **Helpful Tip:** By pressing and holding the up or down arrow, the fast-scroll option will become available on the computer. If you choose to use this fast-scroll option, the numbers will count by 10s.

How to Adjust the Correct Time of Day (P)

To set or change the correct time of day, press the program/enter button 4 times; the computer will display **P**. Use the up or down arrow to scroll through the A.M. and P.M. times. Once the correct time of day is entered, the program/enter button must be pressed again for the computer to accept the new setting.

 **Helpful Tip:** The fast-scroll option is available during this function.

Diagnostics

Display	Description	How to Access
s	Salt Level	Press the program/enter button
A	Salt Alarm	2 times
h	Hour of Regeneration	3 times
P	Present Time of Day	4 times

Troubleshooting Guide

Symptom	Cause	Solution
1. The system fails to regenerate automatically	1. The power supply is plugged into intermittent or dead power source.	1. Connect to a constant power source.
2. The system regenerates at the wrong time	1. The computer is not set properly. 2. The time is off due to daylight savings.	1. Reset the time of day/hour of regeneration. 2. Reset the time of day.
3. Poor water quality	1. The raw water has changed. 2. The bypass valve is open. 3. The power supply is disconnected.	1. Call your RainSoft Dealer for a new water analysis. 2. Close the bypass valve. 3. Plug in the power supply.
4. Loss of water pressure	1. Low pressure to the unit.	1. Bypass the system. If the problem still exists after bypass, it is not related to a RainSoft product. Check your water distribution system. If the problem is resolved after bypass, call your RainSoft Dealer for service.
5. Excessive water in the brine tank and/or salty water	1. The drain line is plugged/restricted. 2. The brine valve is dirty. 3. Low inlet pressure. 4. The computer is not set properly. 5. The injector is plugged.	1. Check the water flow to the drain. Check for crimps in the drain line. Call your RainSoft Dealer for service. 2. Call your RainSoft Dealer for service. 3. Call your RainSoft Dealer to increase the inlet pressure. It must be a minimum of 20 psi. 4. Call your RainSoft Dealer to reset the settings. 5. Call your RainSoft Dealer for service.
6. The system fails to use salt	1. The drain line is plugged/restricted. 2. The injector is plugged. 3. Low inlet pressure. 4. No water in the brine tank.	1. Check the water flow to the drain. Check for crimps in the drain line. Call your RainSoft Dealer for service. 2. Call your RainSoft Dealer for service. 3. Call your RainSoft Dealer to increase the inlet pressure. It must be a minimum of 20 psi. 4. Call your RainSoft Dealer for service.
7. Constant flow to the drain	1. Foreign material in the valve.	1. Call your RainSoft Dealer to clean the valve.

If the troubleshooting guide did not resolve the symptom, please contact your local RainSoft Dealer for service. If you cannot locate your local RainSoft Dealer, please contact RainSoft Customer Service at 1-800-860-7638 or log onto www.rainsoft.com for the name and location of your nearest Dealer.

Valve Exploded View

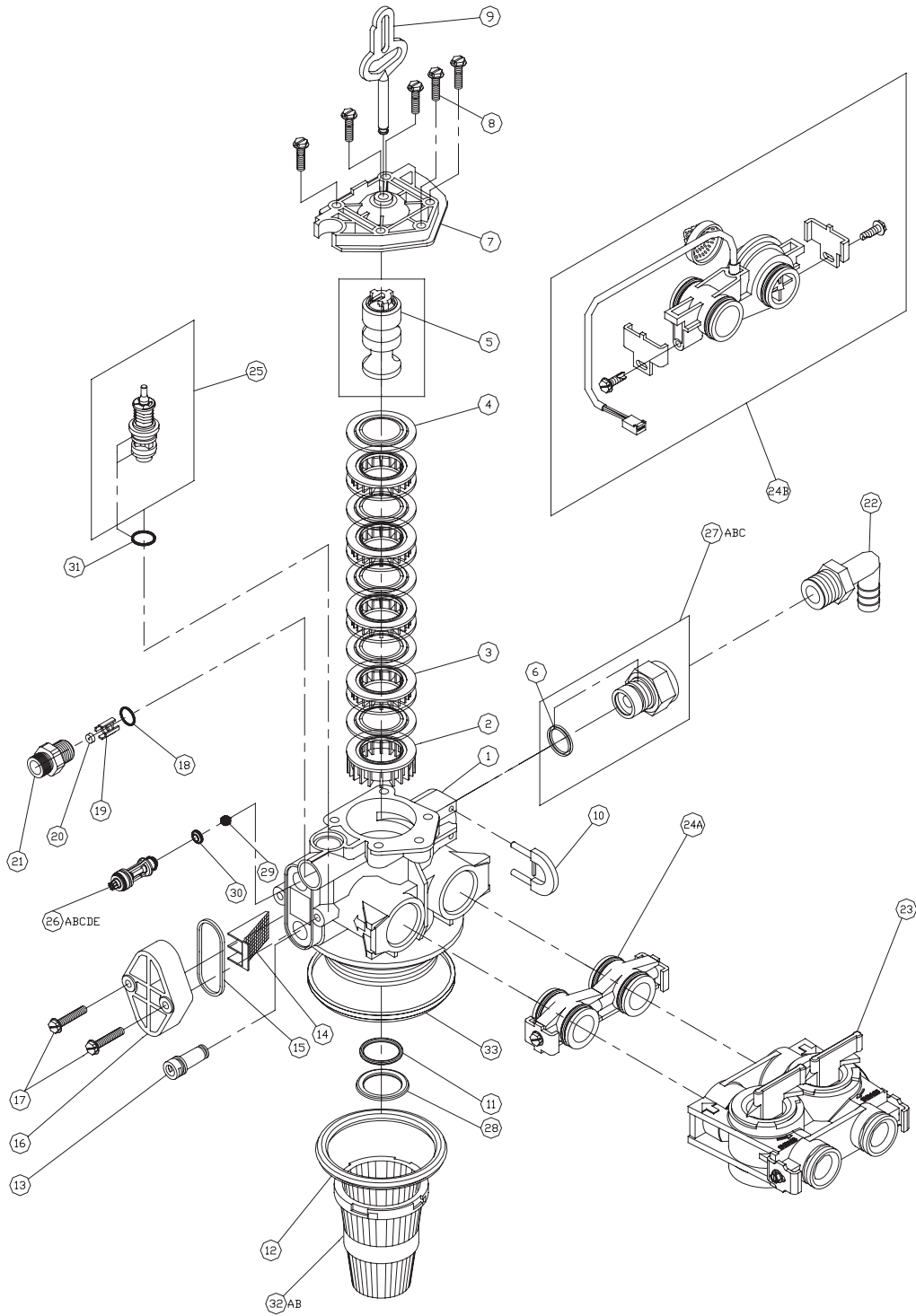

Valve Parts List

Item	Quantity	Part Number	Description
1	1	17863	Composite valve body
2	1	17864	Spacer end
3	4	17865	Internal spacer
4	5	17866	Internal seal
5	1	18160	Retainer & down flow piston
6	1	10258	O-ring - 017
7	1	17869	End plug assembly
8	5	17870	10-24 x .812 screw hex washer head
9	1	17871	Piston rod
10	1	17887	Retainer drain
11	1	17888	O-ring - 121
12	1	17889	O-ring - 336
13	1	17617	Injector plug assembly
14	1	17948	Injector screen
15	1	17949	Injector seal
16	1	17950	Injector cap
17	2	17951	Screw hex washer head 10-24 x 1.0
18	1	17958	O-ring - 015
19	1	17953	Retainer blfc button
20	1	17954	Flow control washer 0.25 gpm
21	1	17957	Adapter blfc 0.25 gpm
22	1	17939	1/2 npt x 1/2 barb poly elbow
23	1	17557	Composite bypass valve
24A	1	17560	3/4" coupling adapter assembly
24B	1	17558	Turbine meter assembly with cable
25	1	17812	Refill shut-off assembly
26A	1	17893	#00 injector assembly
26B	1	17947	#0 injector assembly
26C	1	18194	#1 injector assembly
26D	1	19318	#2 injector assembly
26E	1	19393	#3 injector assembly
27A	1	17991	1.5 drain line flow control assembly
27B	1	17992	2.0 drain line flow control assembly
27C	1	17994	3.0 drain line flow control assembly
28	1	18445	Riser pipe retainer o-ring
29	1	18857	Check ball injector
30	1	18855	Injector seat assembly
31	2	13329	O-ring - 014
32A	1	17941	Diffuser upper basket 1 x .008 red
32B	1	18985	Diffuser upper basket 1 x .02 white
33	1	19328	Tank retainer seal

Control Exploded View

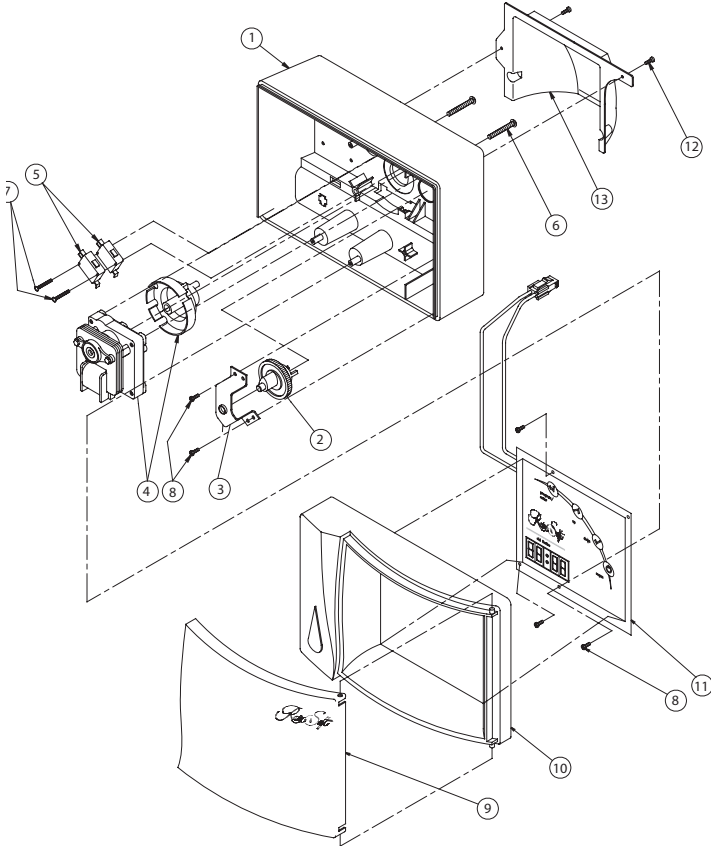

Control Parts List

Item	Quantity	Part Number	Description
1	1	17487	Rear housing
2	1	17501	Brine cam gear
3	1	17492	Brine cam gear bracket
4	1	17537	Valve motor w/computer cam 24v 50/60 hz
5	2	17526	Switch 45 deg actuator gold contact
6	2	17548	10-32 x 1.50 screw pan h phil ss
7	2	18135	4 x 1.25 screw slotted hex washer type 25
8	5	17542	4-20 x .375 screw pan h phil ss
9	1	17853	Front door housing gold
10	1	17855	Front housing gold
11	1	17527	Gold 24v 50/60 hz pcb assembly
12	2	17542	4-20 x .375 screw pan h phil ss
13	1	17490	Rear housing cover

Limited Lifetime Warranty

For as long as you own the equipment

RainSoft Division of AWTP, LLC, believing its

GOLD SERIES WATER TREATMENT SYSTEM

to be of exceptional quality, hereby warrants said equipment to its first purchaser at retail as follows:

THE TREATMENT TANK, VALVE AND SALT CONTAINER ARE WARRANTED AGAINST DEFECTS IN MANUFACTURE FOR THE LIFETIME OF THE FIRST PURCHASER AT RETAIL.

THE ELECTRICAL PARTS ARE WARRANTED AGAINST DEFECTS IN MANUFACTURE FOR FIVE YEARS AND PRO-RATA WARRANTED FOR AN ADDITIONAL FIVE YEARS.

RESINS:

ION-X 34 IS WARRANTED AGAINST DEFECTS IN MANUFACTURE FOR TEN YEARS.

ION-X 100 IS WARRANTED AGAINST DEFECTS IN MANUFACTURE FOR THE LIFETIME OF THE FIRST PURCHASER AT RETAIL.

ION-X 2000 IS WARRANTED AGAINST DEFECTS IN MANUFACTURE FOR THE LIFETIME OF THE FIRST PURCHASER AT RETAIL.

This warranty begins at the time the equipment is first connected for use, and is contingent upon the return of a signed owner's registration card.

This warranty does not require replacement of the entire unit. If the equipment does not perform properly, you should request service from the dealer that sold you the equipment. If you are not satisfied, you should notify our Customer Service Manager. If we are not able to arrange local servicing, you should send the defective part(s) (or, if you prefer, send the entire unit,) directly to the manufacturer, freight prepaid, with proof of purchase and a copy of this warranty. The defective part(s) (or entire unit) will either be repaired or new RainSoft part(s) furnished, for a nominal charge to cover labor, handling, packing and the increase, if any, in the retail price of the part(s) since the date of purchase. Genuine RainSoft parts must be used. Failure to use genuine RainSoft parts will void the warranty and certifications.

This warranty does not include labor charges, and does not cover installation, transportation, or any other claims or torts. Some states do not allow the exclusion or limitation of incidental or consequential damages, so parts of the above limitation or exclusion may not apply to you.

This warranty gives you specific legal rights, and you may also have other rights which vary from state to state. You also have implied warranty rights. In the event of a problem with warranty service or performance, you may be able to go to a small claims court, a State court, or a Federal District Court.

This warranty is void if equipment is not installed and operated according to instructions. It does not apply to damage caused by abuse, accident, neglect, freezing, fire, or other abnormal conditions beyond the company's control. This warranty is void on any part from which the manufacturing date has been removed or made illegible.

Benefits will be provided by various types of RainSoft equipment when installed and operated according to the manufacturer's recommendations. Operational, maintenance and replacement requirements are essential for the product to perform as advertised. All claims are based on the best available information at the time of printing. Manufacturer makes no representations as to the suitability of this equipment for a particular application. Buyer relies entirely on the dealer's recommendations in the purchase of this equipment.

Independent RainSoft dealers may include, together with your RainSoft product, a product or component that is not manufactured by RainSoft or their parent company, AWTP, LLC. Any non-RainSoft product may be covered by the manufacturer of that product, and is not covered by the RainSoft warranty. AWTP, LLC does not warrant that your RainSoft product and the non-RainSoft product will perform properly when used together, and assume no liability therefore.

RainSoft Division of Aquion Water Treatment Products
2080 East Lunt Avenue
Elk Grove Village, Illinois 60007 USA

Installer Specification Sheet

Dealer Name: _____

Phone Number: _____

Installation Number: _____

Installation Date: _____

Model Number: _____

Serial Number: (See Label) _____

Hardness: _____

Iron: _____

TDS: _____

Line Pressure: _____ (psi)

Capacity of the Unit: _____ (grains)

Tank Size: Diameter _____ (inch) Height _____ (inch)

Flow Control Size: (Circle) 1.5 2.0 3.0 (gpm)

Time of Regeneration: (Circle): A.M. P.M.

Starting Capacity Setting: (Circle) 33% 60% 70% 80%

Adjusted Brine Refill Time (1): _____ (minimum)

Adjusted Brine Make-up Time (2): _____ (minimum)

Adjusted Backwash Time (3): _____ (minimum)

Adjusted Brine/Slow Rinse Time (4): _____ (minimum)

Adjusted Fast Rinse Time (5): _____ (minimum)

AMAZON GOLD SERIES MODEL AQC 75 CV

DEMAND INITIATED TREATMENT SYSTEM

- SERVICE FLOW RATE = 9.3 GPM (35.2 LPM)
- DRAIN FLOW RATE: 1.5 GPM (5.7 LPM)
- PSI DROP @ FLOW RATE: 15.0 psi (1.1 kgf/cm²)
- OPERATING PSI OF SUPPLY: 20 psi - 120 psi (1.47 - 8.45 kgf/cm²)
- OPERATING TEMPERATURE: 40° F - 100° F (4.4° C - 38° C)
- ELECTRICAL: 24 VAC, 50/60 Hz (COMPUTER)
- SALT PER REGENERATION: VARIABLE
- EFFICIENCY: 4,470 GRAINS/LBS. SALT @ 3.0 LBS. DOSAGE

CAPACITY AND SALT SETTINGS

CAPACITY	SALT
13,400 GRAINS	@ 3.0 LBS. OF SALT
24,000 GRAINS	@ 7.5 LBS. OF SALT
28,100 GRAINS	@ 11.2 LBS. OF SALT

SOFTENING PERFORMANCE TEST

CHALLENGE	AVERAGE INFLUENT LEVEL	AVERAGE EFFLUENT LEVEL
HARDNESS	350 PPM	9 PPM

NSF/ANSI STANDARD 44 TEST CONDITIONS: 35 ± 5 psi, 60 ± 10°F, pH 7.5 ± 0.5 at service flow rate

ADDITIONAL NOTES

- THE LIST OF SUBSTANCES WHICH THIS TREATMENT DEVICE REDUCES DOES NOT NECESSARILY MEAN THAT THESE SUBSTANCES ARE PRESENT IN YOUR WATER SUPPLY.
- ACTUAL RESULTS MAY VARY DUE TO LOCAL WATER CONDITIONS.
- AN EFFICIENCY RATED WATER SOFTENER IS A DEMAND INITIATED REGENERATION SOFTENER, WHICH ALSO COMPLIES WITH SPECIFIC PERFORMANCE SPECIFICATIONS INTENDED TO MINIMIZE THE AMOUNT OF REGENERATE BRINE AND WATER USED IN ITS OPERATION AND WILL ACHIEVE A RATING OF NOT LESS THAN 3,350 GRAINS OF TOTAL HARDNESS EXCHANGE PER POUND OF SODIUM CHLORIDE SALT AND SHALL NOT DELIVER MORE SALT THAN ITS LISTED RATING. THE EFFICIENCY IS MEASURED BY A LABORATORY TEST DESCRIBED IN NSF/ANSI 44. THE TEST REPRESENTS THE MAXIMUM POSSIBLE EFFICIENCY THAT THE SYSTEM CAN ACHIEVE. OPERATIONAL EFFICIENCY IS THE ACTUAL EFFICIENCY ACHIEVED AFTER THE SYSTEM HAS BEEN INSTALLED AND IS TYPICALLY LESS THAN THE TESTED EFFICIENCY DUE TO INDIVIDUAL APPLICATION FACTORS INCLUDING WATER HARDNESS, WATER USAGE, AND OTHER CONTAMINANTS THAT REDUCE THE SOFTENERS CAPACITY.
- A WATER SOFTENER IS NOT INTENDED TO BE USED FOR TREATING WATER THAT IS MICROBIOLOGICALLY UNSAFE OR OF UNKNOWN QUALITY WITHOUT ADEQUATE DISINFECTION BEFORE AND AFTER THE SYSTEM.
- EFFICIENCY OF THE CONDITIONER IS VALID ONLY AT THE STATED SALT DOSAGE.

THE SYSTEM SHOULD BE INSTALLED IN AN AREA NOT AFFECTED BY EXTREME HEAT, COLD, OR THE ELEMENTS.

THIS SYSTEM MUST BE INSTALLED IN ACCORDANCE WITH ALL APPLICABLE STATE AND LOCAL LAWS AND REGULATIONS.

DO NOT INSTALL SYSTEM WHERE WATER IS MICROBIOLOGICALLY UNSAFE OR OF UNKNOWN QUALITY WITHOUT ADEQUATE DISINFECTION BEFORE OR AFTER THE SYSTEM.

THE SYSTEM CONTAINS AN ION-EXCHANGE MEDIA FOR REMOVING LISTED CONTAMINANTS AND MUST BE REGENERATED PERIODICALLY. PLEASE REFER TO THE OWNERS MANUAL TO DETERMINE THE FREQUENCY OF REGENERATIONS.

PLAIN, WHITE BLOCK SALT IS RECOMMENDED FOR THIS SYSTEM. IF BLOCK SALT IS NOT AVAILABLE, A CLEAN, COARSE OR EXTRA COARSE ROCK OR SOLAR SALT MAY BE USED. DO NOT USE GRANULATED SALT. CONSULT YOUR RAINSOFT DEALER FOR POTASSIUM CHLORIDE USE.

YOUR LOCAL DEALER IS AVAILABLE FOR SERVICE AND WARRANTY PART REPLACEMENTS.

WATER TREATMENT DEVICES SOLD TO RETAIL CONSUMERS IN CALIFORNIA ACCOMPANIED BY CERTAIN HEALTH CLAIMS MUST BE CERTIFIED BY THE STATES OF CALIFORNIA. THE AQC 75 CV IS NOT CERTIFIED IN CALIFORNIA FOR THE PURPOSE OF MAKING HEALTH CLAIMS.

IMPORTANT NOTICE

READ THIS PERFORMANCE DATA SHEET AND COMPARE THE CAPABILITIES OF THIS UNIT WITH YOUR ACTUAL WATER TREATMENT NEEDS. IT IS RECOMMENDED THAT BEFORE PURCHASING A WATER TREATMENT UNIT, YOU HAVE YOUR WATER SUPPLY TESTED TO DETERMINE YOUR ACTUAL WATER TREATMENT NEEDS.



TESTED AND CERTIFIED BY THE WQA TO NSF/ANSI STANDARD 44 FOR THE SPECIFIC PERFORMANCE CLAIMS AS VERIFIED AND SUBSTANTIATED BY TEST DATA

SEE THE OWNERS MANUAL FOR GENERAL OPERATION AND MAINTENANCE REQUIREMENTS.

SEE WARRANTY CARD FOR SPECIFIC WARRANTY INFORMATION.



DEMAND INITIATED

WATER TREATMENT SYSTEM

CALIFORNIA PERFORMANCE DATA SHEET

AMAZON GOLD SERIES MODEL AQC 100 CV DEMAND INITIATED TREATMENT SYSTEM

- SERVICE FLOW RATE = 10.0 GPM (37.8 LPM)
- DRAIN FLOW RATE: 2.0 GPM (7.6 LPM)
- PSI DROP @ FLOW RATE: 12.0 psi (0.9 kgf/cm²)
- OPERATING PSI OF SUPPLY: 20 psi - 120 psi (1.47 - 8.45 kgf/cm²)
- OPERATING TEMPERATURE: 40° F - 100° F (4.4° C - 38° C)
- ELECTRICAL: 24 VAC, 50/60 Hz (COMPUTER)
- SALT PER REGENERATION: VARIABLE
- EFFICIENCY: 4,970 GRAINS/LBS. SALT @ 3.0 LBS. DOSAGE

CAPACITY AND SALT SETTINGS

CAPACITY	SALT
14,900 GRAINS	@ 3.0 LBS. OF SALT
32,300 GRAINS	@ 10.0 LBS. OF SALT
37,700 GRAINS	@ 15.0 LBS. OF SALT

SOFTENING PERFORMANCE TEST

CHALLENGE	AVERAGE INFLUENT LEVEL	AVERAGE EFFLUENT LEVEL
HARDNESS	324 PPM	15 PPM

NSF/ANSI STANDARD 44 TEST CONDITIONS: 35 ± 5 psi, 60 ± 10°F, pH 7.5 ± 0.5 at service flow rate

ADDITIONAL NOTES

- THE LIST OF SUBSTANCES WHICH THIS TREATMENT DEVICE REDUCES DOES NOT NECESSARILY MEAN THAT THESE SUBSTANCES ARE PRESENT IN YOUR WATER SUPPLY.
- ACTUAL RESULTS MAY VARY DUE TO LOCAL WATER CONDITIONS.
- AN EFFICIENCY RATED WATER SOFTENER IS A DEMAND INITIATED REGENERATION SOFTENER, WHICH ALSO COMPLIES WITH SPECIFIC PERFORMANCE SPECIFICATIONS INTENDED TO MINIMIZE THE AMOUNT OF REGENERATE BRINE AND WATER USED IN ITS OPERATION AND WILL ACHIEVE A RATING OF NOT LESS THAN 3,350 GRAINS OF TOTAL HARDNESS EXCHANGE PER POUND OF SODIUM CHLORIDE SALT AND SHALL NOT DELIVER MORE SALT THAN ITS LISTED RATING. THE EFFICIENCY IS MEASURED BY A LABORATORY TEST DESCRIBED IN NSF/ANSI 44. THE TEST REPRESENTS THE MAXIMUM POSSIBLE EFFICIENCY THAT THE SYSTEM CAN ACHIEVE. OPERATIONAL EFFICIENCY IS THE ACTUAL EFFICIENCY ACHIEVED AFTER THE SYSTEM HAS BEEN INSTALLED AND IS TYPICALLY LESS THAN THE TESTED EFFICIENCY DUE TO INDIVIDUAL APPLICATION FACTORS INCLUDING WATER HARDNESS, WATER USAGE, AND OTHER CONTAMINANTS THAT REDUCE THE SOFTENERS CAPACITY.
- A WATER SOFTENER IS NOT INTENDED TO BE USED FOR TREATING WATER THAT IS MICROBIOLOGICALLY UNSAFE OR OF UNKNOWN QUALITY WITHOUT ADEQUATE DISINFECTION BEFORE AND AFTER THE SYSTEM.
- EFFICIENCY OF THE CONDITIONER IS VALID ONLY AT THE STATED SALT DOSAGE.

THE SYSTEM SHOULD BE INSTALLED IN AN AREA NOT AFFECTED BY EXTREME HEAT, COLD, OR THE ELEMENTS.

THIS SYSTEM MUST BE INSTALLED IN ACCORDANCE WITH ALL APPLICABLE STATE AND LOCAL LAWS AND REGULATIONS.

DO NOT INSTALL SYSTEM WHERE WATER IS MICROBIOLOGICALLY UNSAFE OR OF UNKNOWN QUALITY WITHOUT ADEQUATE DISINFECTION BEFORE OR AFTER THE SYSTEM.

THE SYSTEM CONTAINS AN ION-EXCHANGE MEDIA FOR REMOVING LISTED CONTAMINANTS AND MUST BE REGENERATED PERIODICALLY. PLEASE REFER TO THE OWNERS MANUAL TO DETERMINE THE FREQUENCY OF REGENERATIONS.

PLAIN, WHITE BLOCK SALT IS RECOMMENDED FOR THIS SYSTEM. IF BLOCK SALT IS NOT AVAILABLE, A CLEAN, COARSE OR EXTRA COARSE ROCK OR SOLAR SALT MAY BE USED. DO NOT USE GRANULATED SALT. CONSULT YOUR RAINSOFT DEALER FOR POTASSIUM CHLORIDE USE.

YOUR LOCAL DEALER IS AVAILABLE FOR SERVICE AND WARRANTY PART REPLACEMENTS.

WATER TREATMENT DEVICES SOLD TO RETAIL CONSUMERS IN CALIFORNIA ACCOMPANIED BY CERTAIN HEALTH CLAIMS MUST BE CERTIFIED BY THE STATES OF CALIFORNIA. THE AQC 100 CV IS NOT CERTIFIED IN CALIFORNIA FOR THE PURPOSE OF MAKING HEALTH CLAIMS.

IMPORTANT NOTICE

READ THIS PERFORMANCE DATA SHEET AND COMPARE THE CAPABILITIES OF THIS UNIT WITH YOUR ACTUAL WATER TREATMENT NEEDS. IT IS RECOMMENDED THAT BEFORE PURCHASING A WATER TREATMENT UNIT, YOU HAVE YOUR WATER SUPPLY TESTED TO DETERMINE YOUR ACTUAL WATER TREATMENT NEEDS.



TESTED AND CERTIFIED BY THE WQA TO NSF/ANSI STANDARD 44 FOR THE SPECIFIC PERFORMANCE CLAIMS AS VERIFIED AND SUBSTANTIATED BY TEST DATA

SEE THE OWNERS MANUAL FOR GENERAL OPERATION AND MAINTENANCE REQUIREMENTS.

SEE WARRANTY CARD FOR SPECIFIC WARRANTY INFORMATION.

AMAZON GOLD SERIES MODEL AQC 100 CT

DEMAND INITIATED TREATMENT SYSTEM

- SERVICE FLOW RATE = 10.0 GPM (37.8 LPM)
- DRAIN FLOW RATE: 2.0 GPM (7.6 LPM)
- PSI DROP @ FLOW RATE: 13.0 psi (0.9 kgf/cm²)
- OPERATING PSI OF SUPPLY: 20 psi - 120 psi (1.47 - 8.45 kgf/cm²)
- OPERATING TEMPERATURE: 40° F - 100° F (4.4° C - 38° C)
- ELECTRICAL: 24 VAC, 50/60 Hz (COMPUTER)
- SALT PER REGENERATION: VARIABLE
- EFFICIENCY: 4,070 GRAINS/LBS. SALT @ 3.0 LBS. DOSAGE

CAPACITY AND SALT SETTINGS

CAPACITY	SALT
12,200 GRAINS	@ 3.0 LBS. OF SALT
25,700 GRAINS	@ 10.0 LBS. OF SALT
25,800 GRAINS	@ 15.0 LBS. OF SALT

SOFTENING PERFORMANCE TEST

CHALLENGE	AVERAGE INFLUENT LEVEL	AVERAGE EFFLUENT LEVEL
HARDNESS	350 PPM	5 PPM

NSF/ANSI STANDARD 44 TEST CONDITIONS: 35 ± 5 psi, 60 ± 10°F, pH 7.5 ± 0.5 at service flow rate

ADDITIONAL NOTES

- THE LIST OF SUBSTANCES WHICH THIS TREATMENT DEVICE REDUCES DOES NOT NECESSARILY MEAN THAT THESE SUBSTANCES ARE PRESENT IN YOUR WATER SUPPLY.
- ACTUAL RESULTS MAY VARY DUE TO LOCAL WATER CONDITIONS.
- AN EFFICIENCY RATED WATER SOFTENER IS A DEMAND INITIATED REGENERATION SOFTENER, WHICH ALSO COMPLIES WITH SPECIFIC PERFORMANCE SPECIFICATIONS INTENDED TO MINIMIZE THE AMOUNT OF REGENERATE BRINE AND WATER USED IN ITS OPERATION AND WILL ACHIEVE A RATING OF NOT LESS THAN 3,350 GRAINS OF TOTAL HARDNESS EXCHANGE PER POUND OF SODIUM CHLORIDE SALT AND SHALL NOT DELIVER MORE SALT THAN ITS LISTED RATING. THE EFFICIENCY IS MEASURED BY A LABORATORY TEST DESCRIBED IN NSF/ANSI 44. THE TEST REPRESENTS THE MAXIMUM POSSIBLE EFFICIENCY THAT THE SYSTEM CAN ACHIEVE. OPERATIONAL EFFICIENCY IS THE ACTUAL EFFICIENCY ACHIEVED AFTER THE SYSTEM HAS BEEN INSTALLED AND IS TYPICALLY LESS THAN THE TESTED EFFICIENCY DUE TO INDIVIDUAL APPLICATION FACTORS INCLUDING WATER HARDNESS, WATER USAGE, AND OTHER CONTAMINANTS THAT REDUCE THE SOFTENERS CAPACITY.
- A WATER SOFTENER IS NOT INTENDED TO BE USED FOR TREATING WATER THAT IS MICROBIOLOGICALLY UNSAFE OR OF UNKNOWN QUALITY WITHOUT ADEQUATE DISINFECTION BEFORE AND AFTER THE SYSTEM.
- EFFICIENCY OF THE CONDITIONER IS VALID ONLY AT THE STATED SALT DOSAGE.

THE SYSTEM SHOULD BE INSTALLED IN AN AREA NOT AFFECTED BY EXTREME HEAT, COLD, OR THE ELEMENTS.

THIS SYSTEM MUST BE INSTALLED IN ACCORDANCE WITH ALL APPLICABLE STATE AND LOCAL LAWS AND REGULATIONS.

DO NOT INSTALL SYSTEM WHERE WATER IS MICROBIOLOGICALLY UNSAFE OR OF UNKNOWN QUALITY WITHOUT ADEQUATE DISINFECTION BEFORE OR AFTER THE SYSTEM.

THE SYSTEM CONTAINS AN ION-EXCHANGE MEDIA FOR REMOVING LISTED CONTAMINANTS AND MUST BE REGENERATED PERIODICALLY. PLEASE REFER TO THE OWNERS MANUAL TO DETERMINE THE FREQUENCY OF REGENERATIONS.

PLAIN, WHITE BLOCK SALT IS RECOMMENDED FOR THIS SYSTEM. IF BLOCK SALT IS NOT AVAILABLE, A CLEAN, COARSE OR EXTRA COARSE ROCK OR SOLAR SALT MAY BE USED. DO NOT USE GRANULATED SALT. CONSULT YOUR RAINSOFT DEALER FOR POTASSIUM CHLORIDE USE.

YOUR LOCAL DEALER IS AVAILABLE FOR SERVICE AND WARRANTY PART REPLACEMENTS.

WATER TREATMENT DEVICES SOLD TO RETAIL SONSUMERS IN CALIFORNIA ACCOMPANIED BY CERTAIN HEALTH CLAIMS MUST BE CERTIFIED BY THE STATES OF CALIFORNIA. THE AQC 100 CT IS NOT CERTIFIED IN CALIFORNIA FOR THE PURPOSE OF MAKING HEALTH CLAIMS.

IMPORTANT NOTICE

READ THIS PERFORMANCE DATA SHEET AND COMPARE THE CAPABILITIES OF THIS UNIT WITH YOUR ACTUAL WATER TREATMENT NEEDS. IT IS RECOMMENDED THAT BEFORE PURCHASING A WATER TREATMENT UNIT, YOU HAVE YOUR WATER SUPPLY TESTED TO DETERMINE YOUR ACTUAL WATER TREATMENT NEEDS.



TESTED AND CERTIFIED BY THE WQA TO NSF/ANSI STANDARD 44 FOR THE SPECIFIC PERFORMANCE CLAIMS AS VERIFIED AND SUBSTANTIATED BY TEST DATA

SEE THE OWNERS MANUAL FOR GENERAL OPERATION AND MAINTENANCE REQUIREMENTS.

SEE WARRANTY CARD FOR SPECIFIC WARRANTY INFORMATION.

NOTES

NOTES

NOTES



RainSoft Division of Aquion Water Treatment Products
2080 East Lunt Avenue
Elk Grove Village, Illinois 60007
Main Switchboard: 1.847.437.9400
Customer Service: 1.800.860.7638
www.rainsoft.com